

ENTRANCE ELEVATION
TWO SPEED RIGHT HAND DOOR & ENTRANCE
(FRONT)

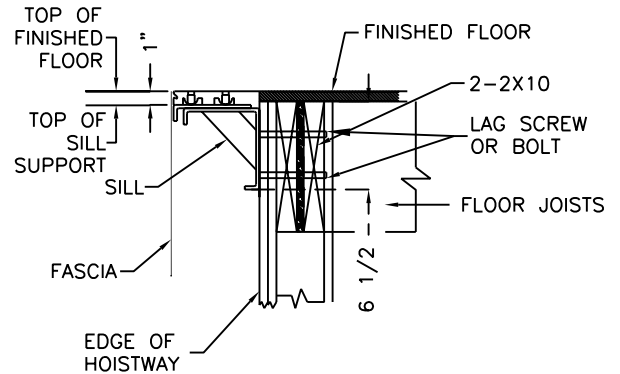
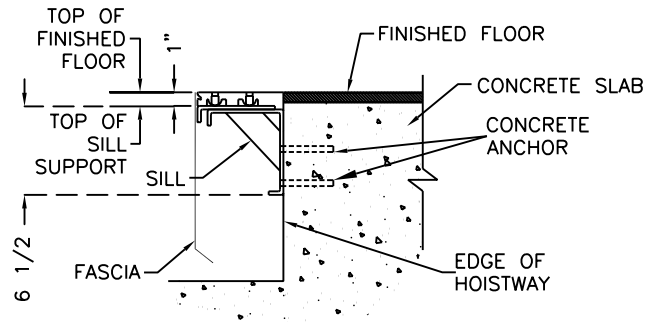

SILL SUPPORT DETAILS

1) HOISTWAY ENTRANCES ARE MANUFACTURED IN ACCORDANCE WITH 1 1/2 HR. FIRE RATED CONSTRUCTION.

2) HOISTWAY WALLS TO HAVE A FIRE ENDURANCE RATING NOT LESS THAN THAT REQUIRED BY RULE 100.1B OF ANSI A17.1 ELEVATOR SAFETY CODE.

3) FURNISHING, INSTALLING AND MAINTAINING THE REQUIRED FIRE RATING OF ELEVATOR HOISTWAY WALLS, INCLUDING THE PENETRATION OF FIRE WALL BY ELEVATOR FIXTURE BOXES, IS NOT THE RESPONSIBILITY OF THE ELEVATOR CONTRACTOR OR ELEVATOR ENTRANCE MANUFACTURER.

*4) HOISTWAY WALLS AT ENTRANCES ARE TO BE BUILT AFTER DOOR SILLS AND FRAMES ARE SET IN PLACE. IF THIS IS NOT FEASIBLE, LEAVE A 48"W X 92"H ROUGH OPENING.

5) FILLING AND GROUTING BY GENERAL CONTRACTOR.

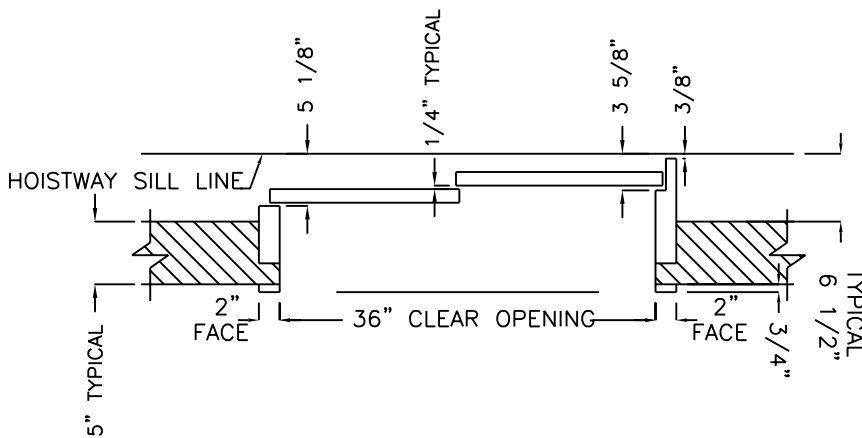

ACCREDITED HOME ELEVATOR

www.acelevator.com

1-800-488-5905